

Welcome! to our world

# GO!

**STRENGTH**  
**WE REDEFINE THE COMPACT CLASS!**  
**RM 120GO! UNLIMITED POTENTIAL**  
**TOP CAPACITY. TOTAL RELIABILITY.**



120GO!



# UNLIMITED POTENTIAL

## TOP CAPACITY. TOTAL RELIABILITY.

### **Outstanding performance and high capacity continuity**

The new RM flagship with an output of up to 350 t/h catapults RUBBLE MASTER into a new league. With this product innovation, RM sets new standards in terms of performance, ease of maintenance, efficiency and innovative design. Weighing in at only 35 tonnes, the RM 120GO! is the most compact crusher of this type.

### **Unique crusher design with excellent final aggregate quality**

The new release system ensures even more homogeneous final aggregate in regular operation and the reliable swinging out of the impact plate when non-crushable materials enter. The crusher is designed so that the impact plates can be exchanged within a short time. This means that the crusher can be equipped for recycling or natural stone applications as required. This is additionally supported by three different rotor speeds which can be easily selected on the operator panel. Moreover, the impact arm can be adjusted on 2 levels to promote even better aggregate distribution.

# HIGHLIGHTS

## THE TECHNICAL HIGHLIGHTS

The RM 120GO! stands out through innovative technology that improves your daily work. The mobile high-performance crusher scores with high reliability, value retention, cost efficiency and productivity, as reflected in the very low operating costs.



### Optional magnet separator

- Height adjustment possible
- Strong permanent magnet
- Seamless vulcanized profile belt for long life time
- Remote control operation
- Reversible from remote control
- Electrically driven for high performance efficiency



### Vibrating hopper

- Single component assembly
- Stepped hopper floor allowing constant and controlled material flow
- Pre-screening for optimised end product and reduction of wear costs
- Load Sensing System for optimised crushing efficiency
- Steplessly controlled from remote control
- Boost function
- Electrically driven



### Safety

- Specified to MSV2010 with relevant emergency stops
- CE Certified manuals
- Covered drive belts
- 2 hand operation required



### Drive

- Diesel-electric concept for less fuel consumption
- Tensioning drums for effective service of the crusher drive
- Generator
- Cyclone pre-filter for optimised air intake
- Maintenance-free cyclone acting as pre-separator
- Ground-based service
- Large mesh cooling system



### Optional side discharge conveyor belt

- Optimum discharge height of 2.55 m
- Quick installation and removal process
- Chevron contour for effective material transport
- Electrically driven
- Selectable between bypass and side conveyor using flap
- Folds into transport position hydraulically



### Pre-screening

- Setup available
  - Grizzly prescreen (standard)
  - Subfloor
  - With integrated bar cage screen for higher capacity prescreening in the vibro-channel



### Main discharge conveyor belt

- Foldable for optimised transport dimensions
- Reverse action to assist with blockage removal
- Operation from remote control
- Seamless vulcanized
- Electrically driven
- Bar cage deflector drum
- Protected by fender plate at exit



### Crusher box

- Single impact arm / swing beam with release system for reduction of blockages
- Impact arm / swing beam vertically adjustable for specialized end product production
- Hydraulic gap adjustment for quick setting
- Crushing gap adjustable on 2 levels from outside
- Unique quick chamber opening system
- Adjustable rotor speeds
- Profiled impact arm / swing beam wear plates for optimum reduction ratios
- 3 crushing regions inside the chamber for multi-staged reduction
- Quick hammer change process
- Optional hammer removal tool available
- Crusher inlet lid opens automatically to reduce blockages
- Double section chain curtain plus rubber curtain at inlet optimising safety



### Optional dust suppression

- Efficient and effective suppression using water jets
- Optional pump offered
- Spray nozzles at conveyor belt and crusher chamber



### Optional hanging mesh screen RM MS125GO! with swivel return or stockpile belt RM RFB7550GO!

- Extremely accurate material splits from 4 - 70 mm
- Swivel RFB for use as re-circulation system or stockpiler
- Mounted in under 15 minutes

# HIGHLIGHTS

## THE TECHNICAL HIGHLIGHTS

Mesh deck screen RM MS125GO! with pivoting refeeding belt. High level of screening accuracy is guaranteed with the RM MS105GO! mesh deck screen, which is mounted on the machine using a handling frame. Oversized grain is transported back to the vibro-channel using the optional RM RFB755OGO! refeeding belt, and then fed back into the crusher.



# TECHNICAL DATA

## RM MS125GO! - MESH SCREEN AND SWIVEL REFEEDING BELT

Output	Up to 300 t/h depending on material
Screening range	0/4 to 0/70 mm
Deck data	1 deck split
Discharge height	2,870 mm
Oversize belt width	500 mm
Fines belt width	1,000 mm
Screen length	3,500 mm
Screen width	1,500 mm

### WITHOUT MACHINE

Transport length MS + RFB	6,700 mm
Transport width MS + RFB	2,940 mm
Transport weight (Including assembly components)	5,500 kg



#### Two screen angles

- High throughput
- Precise sorting accuracy



#### RM screen tension

- 2-piece screen deck tensioned lengthways
- 2 different angles for higher capacity
- Faster and easier screen changes possible



#### Transport

- MS can be transported on the crusher, or separately



#### Windsifter

- Reliably separates lightweight material from value aggregate
- Easily adapted to different operating requirements



#### Pivoting RFB

- Can refeed oversize aggregate to the crusher in a closed circuit, or be pivoted out to feed the oversize aggregate into a stockpile



#### Lowerable MS

- Improved access to screen decks
- Simplified maintenance cycles
- Easy dismantling of the machine

# TECHNICAL DATA

## RM 120GO! - TRACKED MOBILE IMPACT CRUSHER

<b>Output</b>	up to 350 t/h, depending on material
<b>Feed material size</b>	Edge length max. 850 mm
<b>Inlet opening</b>	1,160 x 820 mm
<b>Crusher unit</b>	RUBBLE MASTER impact crusher with 2 or 4 hammers, 3 rotor speeds
<b>Operation</b>	Radio control for crushing and manoeuvring operations
<b>Feed unit</b>	Asymmetric vibro feeder with 4 m <sup>3</sup> and 2 vibrator motors each 3.1 kW, loading height 3,200 mm, effective feed length and width: 3,100 x 2,200 mm Feed control system for automatic crusher load-dependent conveying Hardox 400 wear lining
<b>Prescreening</b>	Screen area 1,200 x 900 mm
<b>Main discharge belt (crushed material)</b>	1,200 mm wide, discharge height 3,600 mm
<b>Discharge belt (screened material)</b>	500 mm wide, discharge height 2,550 mm
<b>Power unit</b>	John Deere (Stage III A at constant engine speed), 6 cylinder, 286 kW at 1.800 rpm, synchronous generator 102 kVA 400 V, electrical outlets 230 V and 400 V for external drives up to 24 kVA, optional engine TIER4f/stage IV
<b>Release system</b>	To remove blockages inside crusher
<b>Magnetic separator</b>	Belt width 1,000 mm
<b>Transport system</b>	Crawler gear
<b>Weight</b>	35,200 kg
<b>Options</b>	Dust suppression using water spray inside crusher and at outlet and belts Diesel filling pump Crusher hammer changing system Cable remote control Central lubrication system Subfloor Active prescreening with bar cage integrated into the vibro-channel Hammer changing device including hammer crane and holder More options available
<b>Add-on equipment MS + RFB:</b>	RM MS125GO! mobile single screen unit with a screen surface of 5.5 m <sup>2</sup> and two belts for precisely screened product Screen unit in combination with an RM RFB7550GO! refeeding belt or stockpiling oversized grain at an angle between 90° and 180° from the machine. Weight 5,500 kg Optional with windsifter

Dimensions in mm. Specifications subject to change in line with technical developments. The machine complies with Guideline 2006/42/EC of the European Parliament.

## DIMENSIONS

### RM 120GO!

#### WORKING POSITION

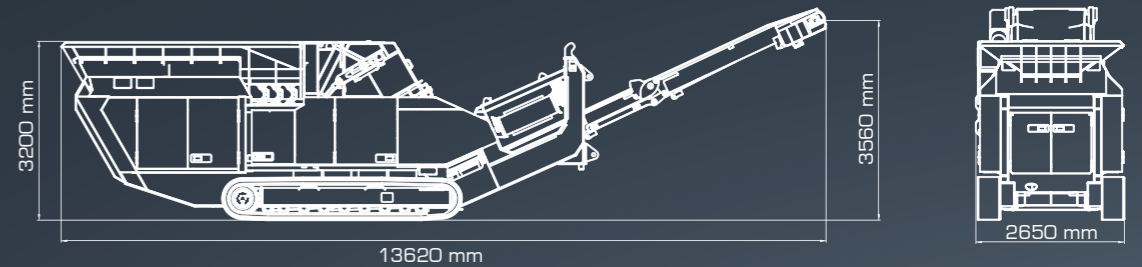

#### TRANSPORT POSITION

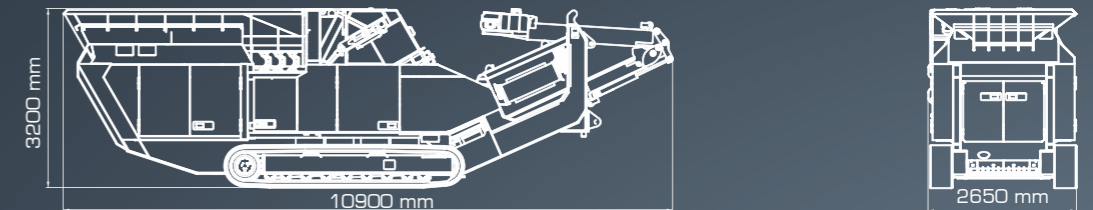

### RM 120GO! + RM MS125GO! + RM RFB7550GO!

#### WORKING POSITION

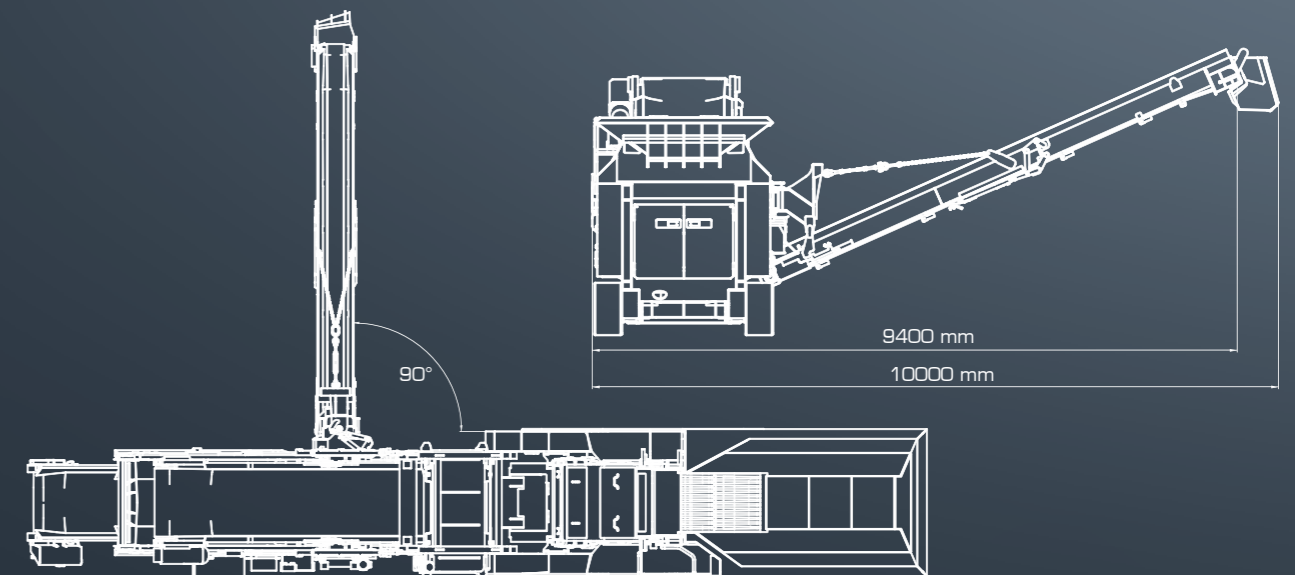
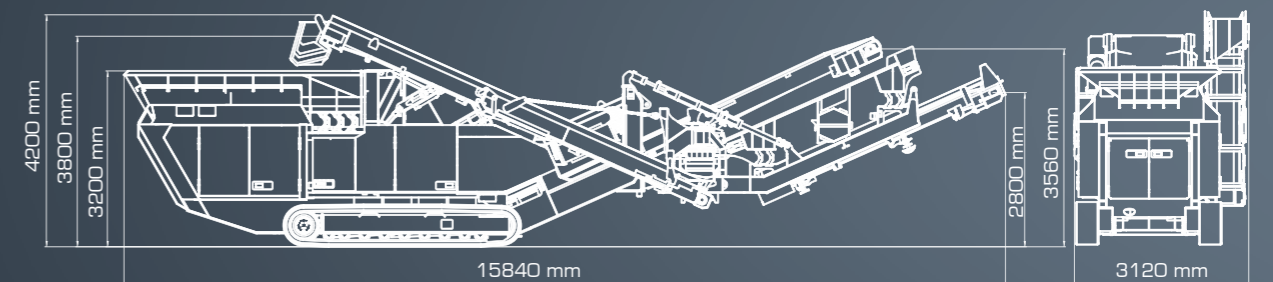

#### TRANSPORT POSITION

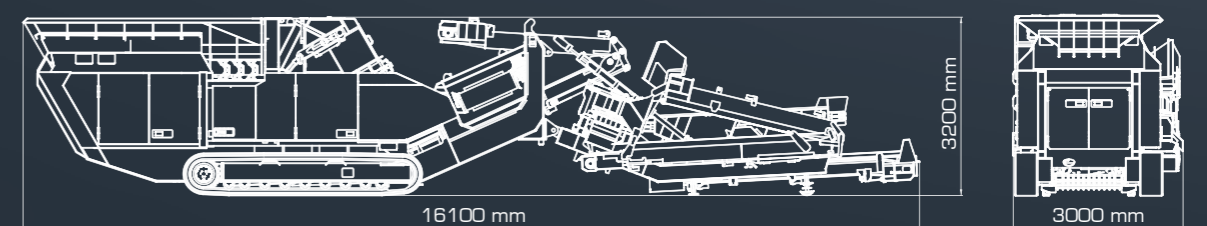

# FIELDS OF APPLICATION

## WIDE RANGE OF APPLICATIONS

### Unique crusher design with excellent final aggregate quality

The new release system ensures even more homogeneous final aggregate in regular operation and the reliable swinging out of the impact plate when non-crushable materials enter. The crusher is designed so that the impact plates can be exchanged within a short time. This means that the crusher can be equipped for recycling or natural stone applications as required. This is additionally supported by three different rotor speeds which can be easily selected on the operator panel.

Additional impact stages can be installed: the mono impact arm is in the pre-crushing area with toothed wear plates as well as in the post-crushing area with 2 smooth wear plates. The impact arm can be extended with an additional stage, which is particularly suitable for crushing natural rock material.



### BROKEN CONCRETE



Residual concrete



Processing



Recycled concrete aggregate



Reused as an additive in concrete production

### BROKEN ASPHALT



Residual asphalt



Processing



Recycled asphalt aggregate



Reused for non-compacted load-bearing surfaces

### CONSTRUCTION DEBRIS



Rubble



Processing



Recycling sand



Reused for backfilling

### NATURAL ROCK



Natural rock



Processing



Crushed material



Reused as building material



# BENEFIT

## 1, 2, 3, GO! – BENEFIT FROM THE WORD GO

### Extremely maintenance-friendly

Remarkably short setup and maintenance times are achieved through the straightforward installation and maintenance of all modules and the optimisation of wear parts. Thanks to the ground based service approach the user has optimum access from ground level to components requiring maintenance.

### Top efficiency

A diesel-electric drive concept enables the direct drive of the RM 120GO! crusher. Optimised crusher geometry, a continuously expanding material flow and new crusher tools make for top efficiency, high-quality end products thanks to a specially designed crusher unit and a very cost-efficient and environment-friendly drive system are further benefits of the RM 120GO!.

1



### Easy transport

The transportation and also the loading and unloading of the RM 100GO! work quickly and uncomplicatedly – so you are ready to work even faster.

2



### Safe ground-based service

The engine which is mounted beneath the vibro feeder can be accessed from three sides and thus enables you to carry out maintenance and servicing safely and efficiently from the ground.

3



### Strong in every environment

The high-performance crusher stands out through high flexibility – even if space is limited – wherever it is used.

GO!



### GO!

Simply push the button and away you go – the innovative GO! principle means you benefit directly and quickly. And, thanks to the standard remote control you can operate all relevant functions on the machine – so you save both time and money.



# RUBBLE MASTER

## WELCOME! TO OUR WORLD

RUBBLE MASTER is the competent partner at your side. We offer you more than innovative machines that are lasting in value – we offer you RUBBLE MASTER Lifetime Support:

### TRAINING PROGRAMMES

We support you with structured training programmes which meet your requirements and turn operators into specialists.

### CONTINUOUS ON-SITE SUPPORT

We offer you permanent on-site support through our partners so you can work with maximum efficiency and productivity at all times.

### SITE ORGANISATION SUPPORT

Based on our many years of experience we, working together with you, optimise the design and settings of the machine and site logistics, which ensures you save costs.

### SPARE PARTS SERVICE

The fast supply of high-quality original RUBBLE MASTER spares and wear parts reflects our commitment to service. Plus it optimises the availability of your machines at the same time.

### RUBBLE MASTER SERVICE CENTRE

Our RUBBLE MASTER SERVICE CENTRE in Linz offers you even greater service expertise and the unrivalled quality of the manufacturer service.



“ Processing mineral materials is more than business to us, it is a way of life. ”

**GERALD HANISCH,**  
RUBBLE MASTER  
FOUNDER & CEO

We are committed to the innovative spirit to be able to offer you products and services at all times which improve your daily business in a lasting way. This passion is your guarantee for machines which fulfil your requirements in every respect. Implemented by a team of experts who are at your side as strong, reliable and always professional partners.





Welcome! to our world



**RUBBLE MASTER HMH GMBH**  
IM SÜDPARK 196, AT 4030 LINZ, AUSTRIA  
TEL: +43 732 73 71 17 - 0  
FAX: +43 732 73 71 17 - 101  
E-MAIL: SALES@RUBBLEMASTER.COM

[WWW.RUBBLEMASTER.COM](http://WWW.RUBBLEMASTER.COM)