

KOMATSU®

HM300-5

Tier 4 Final Engine

ARTICULATED TRUCK



Photos may include optional equipment.

HORSEPOWER

Gross: 332 HP 248 kW
Net: 324 HP 242 kW

PAYLOAD

30.9 US tons 28.0 metric tons

BODY CAPACITY

Heaped (SAE 2:1): 22.4 yd³ 17.1 m³

HM300

WALK-AROUND

HM300-5



Photos may include optional equipment.

HORSEPOWER

Gross: 332 HP 248 kW
Net: 324 HP 242 kW

PAYLOAD

30.9 US tons 28.0 metric tons

BODY CAPACITY

Heaped (SAE 2:1): 22.4 yd³ 17.1 m³



PRODUCTIVITY ON DEMAND

Komatsu Traction Control System (KTCS) automatically engages the inter axle lock and the KTCS braking to provide optimal traction in soft ground conditions.

Selectable working modes for Economy and Power allow machine performance to be adjusted depending on operator's demand and operating conditions.



Komatsu SAA6D125E-7 variable geometry turbocharged and after-cooled 11.04 liter diesel engine is EPA Tier 4 Final emissions certified.

- Heavy duty Selective Catalytic Reduction (SCR) system
- Diesel Exhaust Fluid (DEF) system
- Komatsu Diesel Particulate Filter (KDPF) system
- Heavy duty cooled Exhaust Gas Recirculation (EGR) system
- Electronic control system - seamless to the operator
- Komatsu Variable Geometry Turbocharger (KVGTT) system
- Heavy duty High Pressure Common Rail (HPCR) fuel injection system

Komatsu Variable Geometry Turbocharger (KVGTT) uses a hydraulic actuator to provide optimum air flow under all speed and load conditions.

Komatsu Diesel Particulate Filter (KDPF) and Selective Catalytic Reduction (SCR) systems reduce particulate matter and NOx while providing automatic regeneration that does not interfere with daily operation.

Fluid neutral or better

Fuel & DEF total consumption is less than fuel consumed by prior model.

Advanced diagnostic system continuously monitors machine operation and vital systems to identify machine issues and assist with troubleshooting.

Large LCD color monitor panel:

- 7" high resolution screen
- Provides "Ecology Guidance" for fuel efficient operation

Wide, spacious cab with excellent visibility:

- Center-located operator's seat
- Short nose design
- The rounded engine hood provides improved front visibility.
- Color rearview monitoring system
- The wide cab offers a comfortable operator and passenger environment

For operator comfort:

- Low noise cab through improved sealing with integrated floor.
- Interior noise level 73 dB(A)
- Air suspension seat
- Radio with AUX terminal

KOMTRAX® equipped machines can send location, Service Meter Reading (SMR) and operation maps to a secure website or smart phone utilizing wireless technology. Machines also relay error codes, cautions, maintenance items, fuel & DEF levels, and much more.

Komatsu designed, electronically controlled transmission for a comfortable ride.

F6-R2 counter-shaft type transmission with K-ATOMiCS (Komatsu Advanced Transmission with Optimum Modulation Control System).

High capacity, reliable, continuously cooled, wet type multiple-disc brakes and retarder:

- Fully hydraulic controlled wet multiple-disc brakes
- Retarder absorbing capacity (continuous descent) 392 kW **526 HP**

Hydro-pneumatic suspension for all terrains.

The hydro-pneumatic suspension on both front and rear suspensions assures a comfortable ride even over rough terrain.

Easy-to-load body:

- Heaped capacity 17.1 m³ **22.4 yd³**
- Low loading height 2830 mm **9'3"**
- High strength body constructed of thick wear-resistant steel having 400 Brinell hardness.

PERFORMANCE FEATURES

KOMATSU NEW ENGINE TECHNOLOGIES

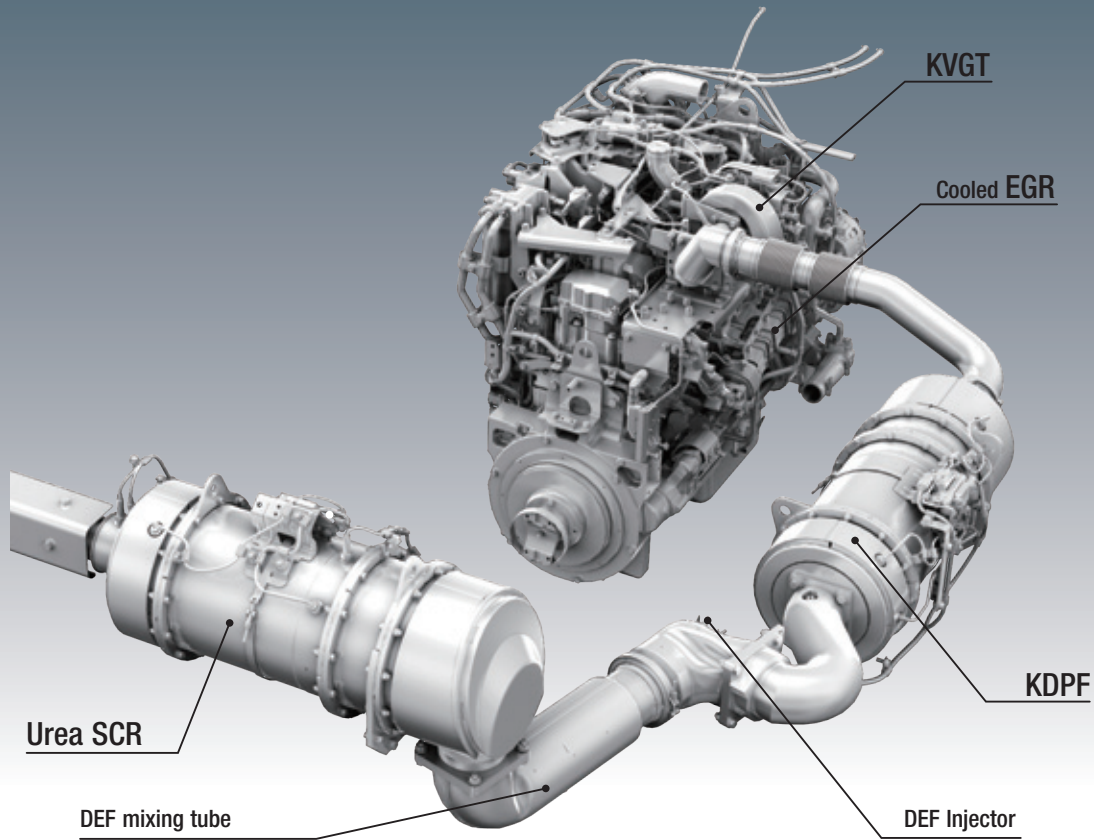

New Tier 4 Final Engine

The Komatsu SAA6D125E-7 engine is EPA Tier 4 Final emissions certified and provides exceptional performance while reducing fuel consumption. Based on Komatsu proprietary technologies developed over many years, this new diesel engine reduces nitrogen oxides (NOx) by more than 80% when compared to Tier 4 interim levels. Through the in-house development and production of engines, electronics, and hydraulic components, Komatsu has achieved great advancements in technology, providing high levels of performance and efficiency in virtually all applications.

Technologies Applied to New Engine Heavy-duty aftertreatment system

This new system combines a Komatsu Diesel Particulate Filter (KDPF) and Selective Catalytic Reduction (SCR). The SCR NOx reduction system injects the correct amount of DEF at the proper rate, thereby decomposing NOx into non-toxic water (H₂O) and nitrogen gas (N₂).

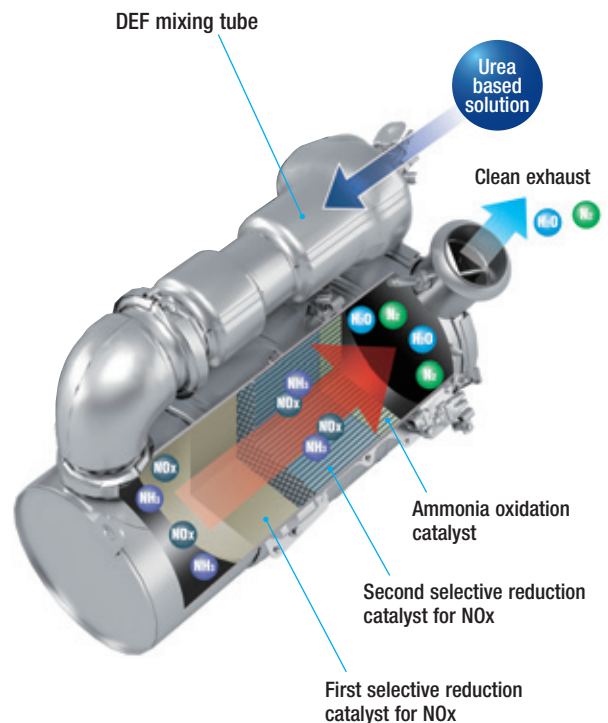

Heavy-duty cooled Exhaust Gas Recirculation (EGR) system

The system recirculates a portion of exhaust gas into the air intake and lowers combustion temperatures, thereby reducing NOx emissions. EGR gas flow has been decreased for Tier 4 Final with the addition of SCR technology. The system achieves a dynamic reduction of NOx, while helping reduce fuel consumption below Tier 4 Interim levels.

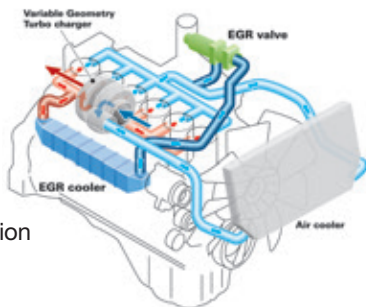

Komatsu Variable Geometry Turbocharger (KVGT) system

The KVGT system features proven Komatsu designed hydraulic technology for variable control of air-flow and supplies optimal air according to load conditions. The upgraded version provides better exhaust temperature management.

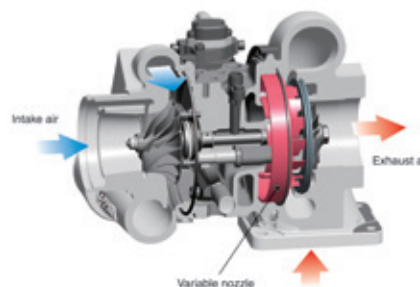

Advanced Electronic Control System

The electronic control system performs high-speed processing of all signals from sensors installed in the vehicle providing total control of equipment in all conditions of use. Engine condition information is displayed via an on-board network to the monitor inside the cab, providing necessary information to the operator. Additionally, managing the information via KOMTRAX helps customers keep up with required maintenance.

Heavy-Duty High-Pressure Common Rail (HPCR) Fuel Injection System

The system is designed to achieve an optimal injection of high-pressure fuel by means of computerized control, providing close to complete combustion to reduce PM emissions. While this technology is already used in current engines, the new system uses high pressure injection, thereby reducing both Particulate Matter (PM) emissions and fuel consumption over the entire range of engine operating conditions. The Tier 4 Final engine has advanced fuel injection timing for reduced fuel consumption and lower soot levels.

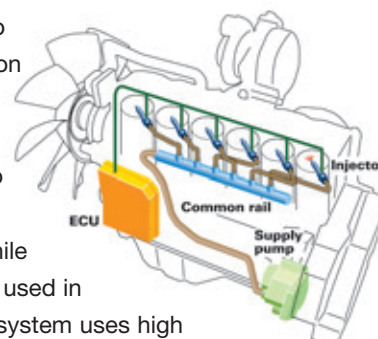

PERFORMANCE FEATURES

Low Fuel Consumption

A variable displacement piston pump consumes engine power only as needed to eliminate unnecessary Power Take-Off (PTO) inefficiencies. Design improvements to the drive axles as well as the transmission have been implemented to reduce driveline parasitic losses. The electronic engine control has been updated with the inception of the SCR technology to conform to EPA Tier 4 Final emissions standards. All of these factors combine to allow for the new HM300 to operate at the same performance level as its predecessor while improving fuel efficiency. The quantity of diesel fuel and DEF consumed by the HM300-5 is less than the quantity of fuel alone consumed by the previous model.

Komatsu Auto Idle Shutdown

Komatsu auto idle shutdown automatically shuts the engine down after idling for a set period of time to reduce unnecessary fuel consumption and exhaust emissions. The amount of time before the engine is shutdown can be easily programmed from 5 to 60 minutes.



Selectable Working Modes

The operator can choose between two working modes, Economy Mode or Power Mode, according to their work demand and conditions.

Power mode



Appropriate for higher production jobs and uphill hauling applications. The power mode increases the engine maximum output and raises the upshift and downshift engine speeds during operation.

Economy mode



Appropriate for lighter work on flat ground. The economy mode lowers the engine maximum output along with lowering the upshift and downshift engine speeds during operation.



Large Capacity Body

The HM300-5 has a heaped body capacity of 17.1 m³ **22.4 yd³**. The low loading height of 2830 mm **9'3"** enables easy loading. The body is built of high strength, wear-resistant steel with a Brinell hardness of 400 and the body shape provides excellent load stability. HM300's frame employs a rigid box structure utilizing high tensile strength steel, and is rugged enough for the toughest jobs.



Komatsu Designed Electronically Controlled Countershaft Transmission

The Komatsu designed electronically controlled transmission called K-ATOMiCS has been a success in Komatsu's dump trucks. The electronic clutch modulation system ensures proper clutch pressure when the clutch is engaged. The total control system controls both the engine and the transmission by monitoring the vehicle conditions. This high technology system assures smooth shifts with minimal shock and maximizes the power train life.





Komatsu Traction Control System (KTCS)

The KTCS was developed by Komatsu to allow for maximum machine performance in soft and slippery ground conditions. Komatsu leveraged its prior experience with the traction control systems in bulldozers and rigid dump trucks to develop this system for use in articulated dump trucks. The KTCS monitors the wheel speeds on the front and middle axles. If the system detects wheel slip, it will automatically engage the inter axle lock to improve machine performance. If the machine continues to detect wheel slip it will brake the wheel that slip was detected on. It will continually monitor the wheel speeds and engage the brakes as necessary. KTCS is automatically activated and deactivated. The inter-axle lock can also be engaged by the operator via a rocker switch located on the dash panel.

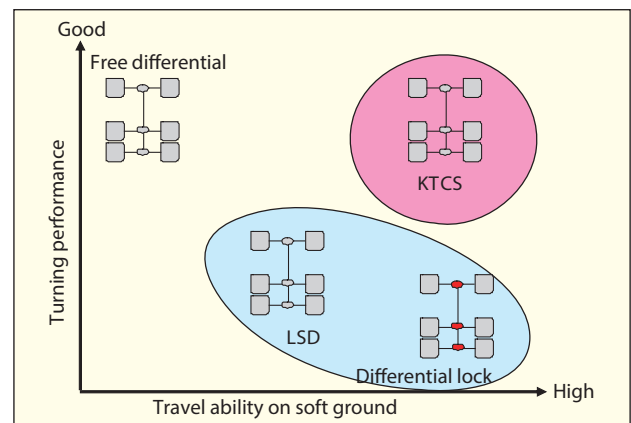
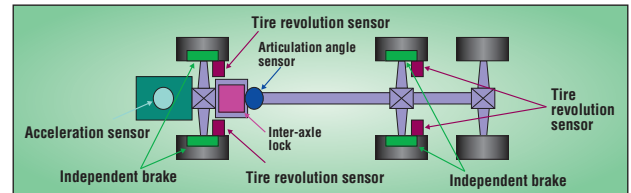

Payload Meter (PLM)

A payload meter is included as standard equipment on the new HM300-5. The payload tonnage is displayed on the Machine Monitor and is visible to the haul truck operator. An external display lamp mounted on the top of the cab communicates payload status to the loader operator. The external display lamp indicator lights are visible from both sides of the truck so it is always in sight of the loader operator.

PLM data is transmitted by KOMTRAX and can be accessed via the internet. Detailed data is stored in the truck's controller and can be directly downloaded from the truck to a PC.



External display lamp

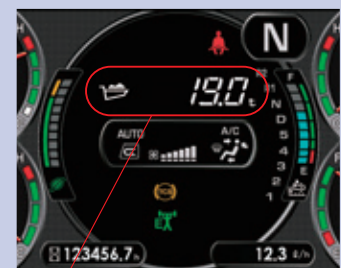

Payload display

GENERAL FEATURES



HM300-5

Rear View Monitoring System

The rear view camera and monitor are equipped as standard.



Rear view monitor



Rear view camera

Center-located Operator Seat

Placing the seat at the center of the operator's cabin provides a wide view of the working area.



Short Nose

The layout of the cooling system allows for a short nose shape and increases the operator's field of view.

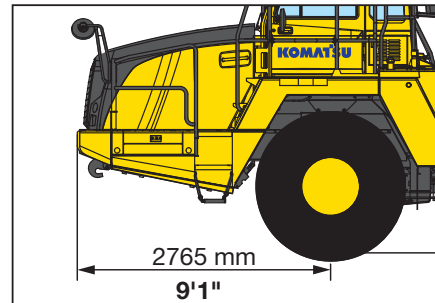

Round Convex Mirrors and Standard Heated Rear View Mirrors

Round convex mirrors provide a wide viewing angle directly in front of the hood. The heated rear view mirrors can be easily folded and are standard.

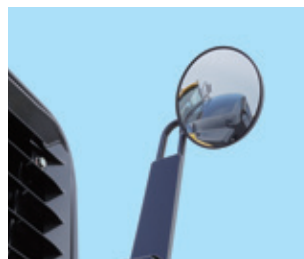

Heated mirror (standard)

Built-in ROPS/FOPS Cab

These structures conform to ISO 3471 ROPS (Roll-Over Protective Structure) standard, and ISO 3449 FOPS (Falling Objects Protective Structure : Level II) standard.

Secondary Engine Shutdown Switch

The engine shutdown switch is added in the cab for emergency use.



LED Rear Combination Lamps (Standard)

Long-life LED stop, tail and turn signal lamps are standard.



LED lamp

Hydraulically Controlled Wet Multiple-disc Brakes and Retarder

Wet multiple-disc brakes with proven performance in other Komatsu dump trucks are tailored for use in the HM300-5. The large-capacity, continuously cooled, wet-multiple disc brakes also function as a highly responsive retarder which gives the operator greater confidence at higher speeds when travelling downhill.

Retarder Absorbing Capacity (continuous descent):
392 kW **526 HP**

Secondary Steering

The secondary steering system is automatically activated if the hydraulic pressure of the steering hydraulic circuit lowers due to a failure in the hydraulic system. This can also be activated manually by the secondary steering switch in the cab. The pilot lamp on the LCD monitor tells the operator that the system is operable when turning the key switch on.

Conform to : ISO 5010, SAE J1511

Ground Clearance

The lowest surface of the hitch is higher than the front axle differential gear housing, maximizing the HM300's ground clearance.

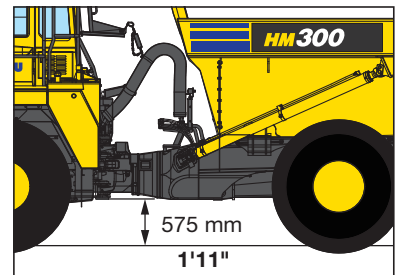

WORKING ENVIRONMENT



HM300-5

Ergonomic Comfort

Ergonomically designed curved dashboard allows switches to be arranged so that they are in easy reach of the operator.

Machine monitor



Color rear view monitor



Multi-switch panel



Low Noise Design

The large cab is mounted with Komatsu's unique ROPS/FOPS viscous mounts. The low-noise engine, hydraulically driven fan, and hydraulic pumps are mounted with rubber cushions, and the cab sealing is designed to provide a quiet, low-vibration, dustproof, and comfortable operating environment.

Operator's ear noise (ISO6396) 73 dB (A)

Dynamic noise level (outside) 108 dB (A)

Air Suspension Seat

The air suspension, fabric-covered seat is adjustable to the operator's weight and is provided standard. The air suspension seat dampens vibrations transmitted from the machine and reduces operator fatigue. The seat is heated for operator comfort.



3 Point Seat Belt

A three-point seat belt is standard equipment. The seat belt can be converted to a two-point lap belt.



Foldable Passenger Seat

The cushion and the back rest of the passenger seat are foldable. Folding the cushion allows the operator to easily come in and out of the cab and allows easy access to the recirculation filter of the air conditioner. Folding the backrest allows easy access to the storage behind the seat.

Tilt-away Steering Column

The tilt steering column and telescopic steering wheel allow the operator to set the steering wheel to the desired position. The tilt mechanism incorporates a spring-assist for easy adjustment.



Radio with AUX Terminal

By connecting an auxiliary device to this plug, the operator can hear sound through the speakers in the cab.

Two DC12V Electrical Outlets

Two DC12 volt outlets are standard in the operators cab. A 12 volt cigarette lighter is located on the front side of the right console and an additional 12 volt outlet is located on the rear right corner behind the operator seat.

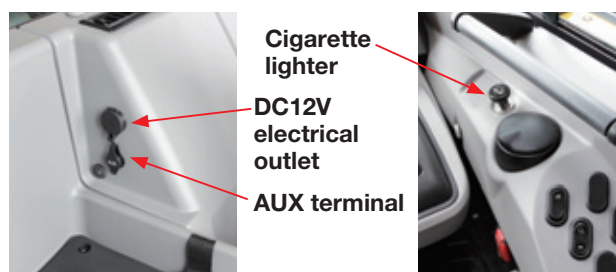

Hydro-pneumatic Suspension

The front axle hydro-pneumatic suspension employs "De Dion" type design, allowing the machine to ride more smoothly over rough terrain. The rear-axles are mounted on a dynamic equalizer structure equipped with hydro-pneumatic suspension. The entire suspension system delivers a comfortable ride and maximizes productivity.

Electronic Hoist Control Lever

The control lever is short in travel and can be operated with a light effort. A "Kick-out function" eliminates a need to hold the lever in "raise" position. Furthermore, body seating shock is significantly reduced because a sensor detects the body just before seating on the frame and reduces the lowering speed.



INFORMATION & COMMUNICATION TECHNOLOGY

HM300-5

Ecology Guidance

The monitor panel provides guidance to the operator to help promote energy saving operation. For example, if the operator stops the machine for a long period of time with the engine idling, the message “Avoid excessive engine idling” is displayed on the monitor panel.

The ecology guidance function displays six (6) messages:

- Avoid Excessive Engine Idling
- Release the Hoist Lever
- Operating the Accelerator Pedal with Brake Actuated Lowers Fuel Economy
- Shift Up
- Avoid Operating the Accelerator Pedal with the Body Moving Down
- Avoid Hard Use of Steering

Ecology Gauge

The ecology gauge indicates a momentary fuel consumption rate during operation. Operating the machine by keeping the gauge within the green zone leads to energy-saving operation.



Energy Saving Operation Guide

The operator can check the operation record, ecology guidance record, and fuel consumption record. The Operation Records indicate the status of the machine for the current day. The Ecology Guidance Records displays the number of occurrences of each guidance message. During operation, it is requested to reduce the number of occurrences of each guidance message in order to achieve energy-saving operation. The Average Fuel Consumption Logs graph the fuel consumption for the previous 12 hours (based on service meter reading) and daily fuel consumption for the previous 7 days.

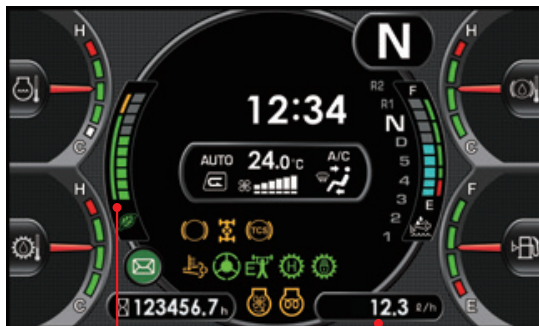

Ecology gauge

Fuel consumption gauge



Operation Records



Ecology Guidance Records

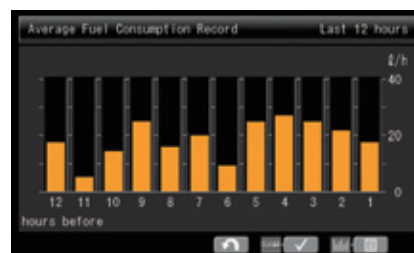

Average Fuel Consumption Record

Machine Monitor

The machine monitor displays various machine information and allows for various settings of the machine.

Switch panel

The switch panel is used to select various LCD unit screens and the air conditioner control screen.

By using the switch panel, you can display various user menus on the LCD unit screen and access the settings of the machine.

Large Multi-Lingual LCD Monitor

A large user-friendly color monitor provides excellent screen visibility through the use of a TFT liquid crystal display that can easily be read at various angles and lighting conditions. A keypad provides simple and easy navigation to machine operation information.

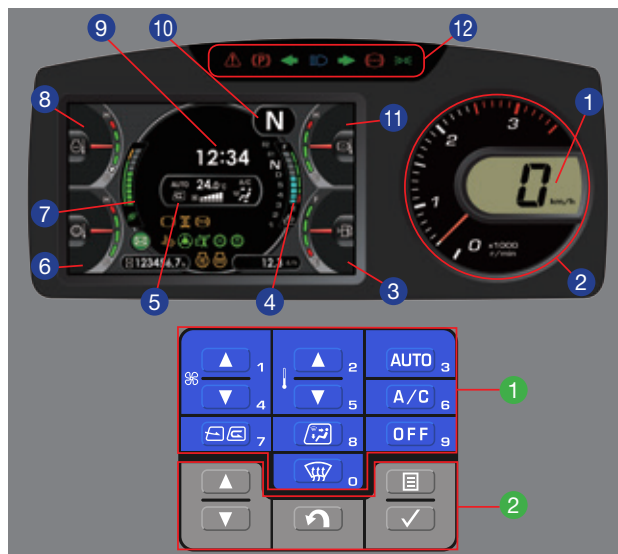

Machine Monitor

- 1 Speedometer
- 2 Engine tachometer
- 3 Fuel gauge
- 4 DEF level gauge
- 5 Air conditioner display
- 6 Torque converter oil temperature gauge
- 7 Ecology gauge
- 8 Engine coolant temperature gauge
- 9 Clock
- 10 Shift indicator
- 11 Retarder oil temperature gauge
- 12 LED indicator

Switch Panel

- 1 Air conditioner switches / Numeral key pad
- 2 Function switches

1 Ecology Guidance

- Operation records
- Ecology guidance records
- Average fuel consumption record
- Configurations

2 Machine setting / information

- Radiator fan reverse mode
- CAC fan reverse mode
- KTCS setting etc.

3 KDPF regeneration

- Setting regeneration disable
- Operation of manual stationary regeneration

4 SCR information

5 Maintenance

- Check and reset of various maintenance intervals

6 Monitor setting

- Language setting (27 languages)
- Rear view monitor setting
- Measurement unit setting
- Screen brightness adjustment etc.

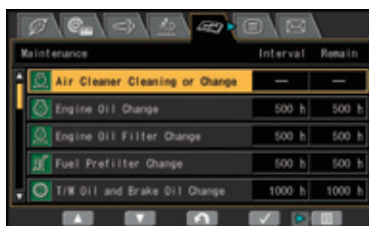
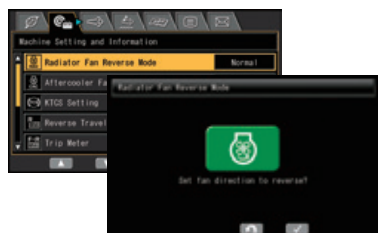

MAINTENANCE FEATURES

Ground Access to Filters

The oil filters of the transmission and the brake systems can be serviced from ground level.



Tiltable Cab with Power Tilt

The cab can be tilted rearward by 29 degrees to provide easy access to the engine and transmission for service. Electrically-operated cab tilt is standard.

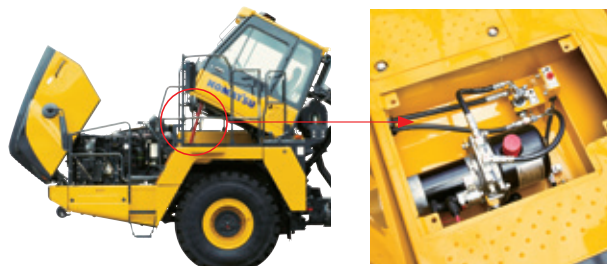

Reversible Fan

The radiator fan and Charge Air Cooler (CAC) fan are driven hydraulically. You can reverse the rotation of the radiator fan and/or CAC fan to blow off dirt and dust accumulated on respective cores. Fan reverse mode can be controlled on the monitor.

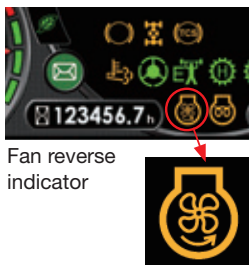

Round Design Engine Hood and Grill

The lightweight resin hood is easy to open and close. The CAC cover is also made of resin.

Electric Fuel Priming Pump

Electric fuel priming pump is equipped as standard.



Easy Access DEF Tank

Located to the rear of the fuel tank, and easy to access.

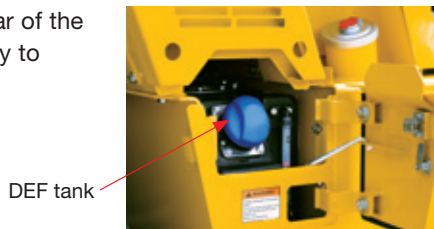

DEF tank

Battery Disconnect Switch

For machine service work a battery disconnect switch is standard on the HM300-5. This switch can be accessed from ground level.



Maintenance Information

DEF Level and Refill Timing

The DEF level gauge is displayed continuously on the right side of the monitor screen. In addition, when the refill timing* is reached, the DEF low level guidance appears as a pop up display to inform the operator in real time.

* The Tier 4 Final emission requirements for off-road engines stipulates that the engine output has to be limited when DEF level becomes very low.



DEF level gauge

KOMTRAX EQUIPMENT MONITORING

GET THE WHOLE STORY WITH
KOMTRAX[®]

✓ **WHAT**

- KOMTRAX is Komatsu's remote equipment monitoring and management system
- KOMTRAX **continuously monitors and records** machine health and operational data
- Information such as fuel consumption, utilization, and a detailed history **lowering owning and operating cost**

✓ **WHEN**

- Know when your machines are **running or idling** and make decisions that will improve your fleet utilization
- Detailed movement records ensure you know when and where your equipment is moved
- Up to date records allow you to **know when maintenance is due** and help you plan for future maintenance needs

✓ **WHERE**

- KOMTRAX data **can be accessed virtually anywhere** through your computer, the web or your smart phone
- Automatic alerts keep fleet managers up to date on the latest machine notifications

✓ **WHY**

- Knowledge is power - **make informed decisions** to manage your fleet better
- Knowing your idle time and fuel consumption will help maximize your machine efficiency
- **Take control of your equipment** - any time, anywhere

✓ **WHO**

- KOMTRAX is **standard** equipment on all Komatsu construction products



KOMTRAX[®]

For construction and compact equipment.

KOMTRAX Plus[™]

For production and mining class machines.

KOMATSU PARTS & SERVICE SUPPORT



Every new Komatsu Tier 4 Final construction machine is covered.

The Komatsu CARE program covers all new Komatsu Tier 4 Final construction equipment, whether rented, leased or purchased. For the first 3 years or 2,000 hours, whichever occurs first, you'll receive:

- Regular service at 500, 1,000, 1,500 and 2,000-hr. intervals
- DEF tank breather element replacement at 1,000 hours
- DEF and CCV filters replacement at 2,000 hours
- 50-point inspection by factory-trained technician at each scheduled interval
- Technician labor
- Fluids, oils, coolant, filters, SCR screen, tank breather and parts
- Technician travel to and from your equipment location

Plus two complimentary scheduled KDPF exchanges and SCR system service for 5 years-no hours limits.*

Service will be performed by a Komatsu Distributor and only Komatsu genuine fluids and filters will be used.

Komatsu CARE® services are available from every Komatsu Distributor in the U.S. and Canada.



Komatsu CARE® – Extended Coverage

- Extended Coverage can provide peace of mind by protecting customers from unplanned expenses that effect cash flow
- Purchasing extended coverage locks-in the cost of covered parts and labor for the coverage period and helps turn these into fixed costs



Komatsu Parts Support

- 24/7/365 to fulfill your parts needs
- 9 parts Distribution Centers strategically located across the U.S. and Canada
- Distributor network of more than 300 locations across U.S. and Canada to serve you
- Online part ordering through Komatsu eParts
- Remanufactured components with same-as-new warranties at a significant cost reduction



Komatsu Oil and Wear Analysis (KOWA)

- KOWA detects fuel dilution, coolant leaks, and measures wear metals
- Proactively maintain your equipment
- Maximize availability and performance
- Can identify potential problems before they lead to major repairs
- Reduce life cycle cost by extending component life

* Some exclusions apply. Please contact your Komatsu distributor for specific program details.

SPECIFICATIONS



ENGINE

Model.....Komatsu SAA6D125E-7*
 Type.....Water-cooled, 4-cycle
 Aspiration.....Turbo-charged, after-cooled, cooled EGR
 Number of cylinders..... 6
 Bore.....125 mm **4.92"**
 Stroke.....150 mm **5.91"**
 Piston displacement..... 11.0 ltr **671 in³**
 Horsepower:
 SAE J1995.....Gross 248 kW **332 HP**
 ISO 9249 / SAE J1349.....Net 242 kW **324 HP**
 Rated rpm.....2000 rpm
 Fan drive type.....Hydraulic driven
 Maximum torque.....171 kg•m **1,237 ft lbs**
 Fuel system.....Direct injection
 Governor.....Electronically controlled
 Lubrication system:
 Method.....Gear pump, force-lubrication
 Filter.....Full-flow type
 Air cleaner.....Dry type with double elements and
 precleaner, plus dust indicator

*EPA Tier 4 Final emissions certified



TRANSMISSION

Torque converter.....3-elements, 1-stage, 2-phase
 Transmission.....Full-automatic, counter-shaft type
 Speed range.....6 speeds forward and 2 reverse
 Lockup clutch.....Wet, single-disk clutch
 Forward.....Torque converter drive in 1st gear,
 direct drive in 1st lockup and all higher gears
 Reverse.....Torque converter drive and direct drive in all gear
 Shift control.....Electronic shift control with automatic
 clutch modulation in all gear
 Maximum travel speed.....58.6 km/h **36.4 mph**



AXLES

Full time all wheel drive with Komatsu Traction Control System (K-TCS)
 Final drive type.....Planetary gear
 Ratios:
 Differential.....3.154
 Planetary.....4.667



SUSPENSION SYSTEM

Front.....Hydro-pneumatic suspension
 Rear.....Combined hydro-pneumatic
 and rubber suspension system



STEERING SYSTEM

Type.....Articulated type, fully hydraulic power steering
 with two double-acting cylinders
 Secondary steering.....Automatically actuated,
 electrically powered
 Standard.....ISO5010, SAE J1511
 Minimum turning radius, wall to wall.....8.10 m **26' 7"**
 Articulation angle.....45° each direction



CAB

Standard.....ISO3449 (FOPS)
 ISO3471 (ROPS)



BRAKES

Service brakes.....Full-hydraulic control, oil-cooled
 multiple-disc type on front and center axles
 Standard.....ISO3450
 Parking brake.....Spring applied, caliper disc type
 Retarder.....Front and center axle brakes act as retarder



MAIN FRAME

Type.....Articulated type, box-sectioned
 construction on front and rear
 Connected by strong torque tubes.



BODY

Capacity:
 Struck.....13.4 m³ **17.5 yd³**
 Heaped (2:1, SAE).....17.1 m³ **22.4 yd³**
 Payload.....28.0 metric tons **30.9 U.S. tons**
 Material.....130 kg/mm² **184,925 psi**
 high tensile strength steel

Material thickness:
 Bottom.....14 mm **0.55"**
 Front.....8 mm **0.31"**
 Sides.....12 mm **0.47"**
 Target area
 (inside length x width) .. 5250 mm x 2685 mm **17' 3" x 8' 10"**
 Heating.....Exhaust heating (option)



HYDRAULIC SYSTEM

Hoist cylinder.....Twin, telescopic type
 Relief pressure.....30.4 MPa 310 kg/cm² **4,409 psi**
 Hoist time.....10.5 sec



WEIGHT (APPROXIMATE)

Empty weight.....25,395 kg **55,986 lbs**
 Gross vehicle weight.....53,475 kg **117,892 lbs**
 Weight distribution:
 Empty: Front axle.....58.9%
 Center axle.....22.5%
 Rear axle.....18.6%
 Loaded: Front axle.....30.8%
 Center axle.....36.0%
 Rear axle.....33.2%



TIRES

Standard tire.....23.5 R25



SERVICE REFILL CAPACITIES

Fuel tank.....388 ltr **102.5 U.S. gal**
 DEF tank.....32.8 ltr **8.7 U.S. gal**
 Engine oil.....35 ltr **9.2 U.S. gal**
 Torque converter, transmission and
 retarder cooling.....80 ltr **21.1 U.S. gal**
 Differentials (total).....71.5 ltr **18.9 U.S. gal**
 Final drives (total).....23 ltr **6.1 U.S. gal**
 Hydraulic system.....103 ltr **27.2 U.S. gal**
 Suspension (total).....10.4 ltr **2.7 U.S. gal**

SPECIFICATIONS



DIMENSIONS

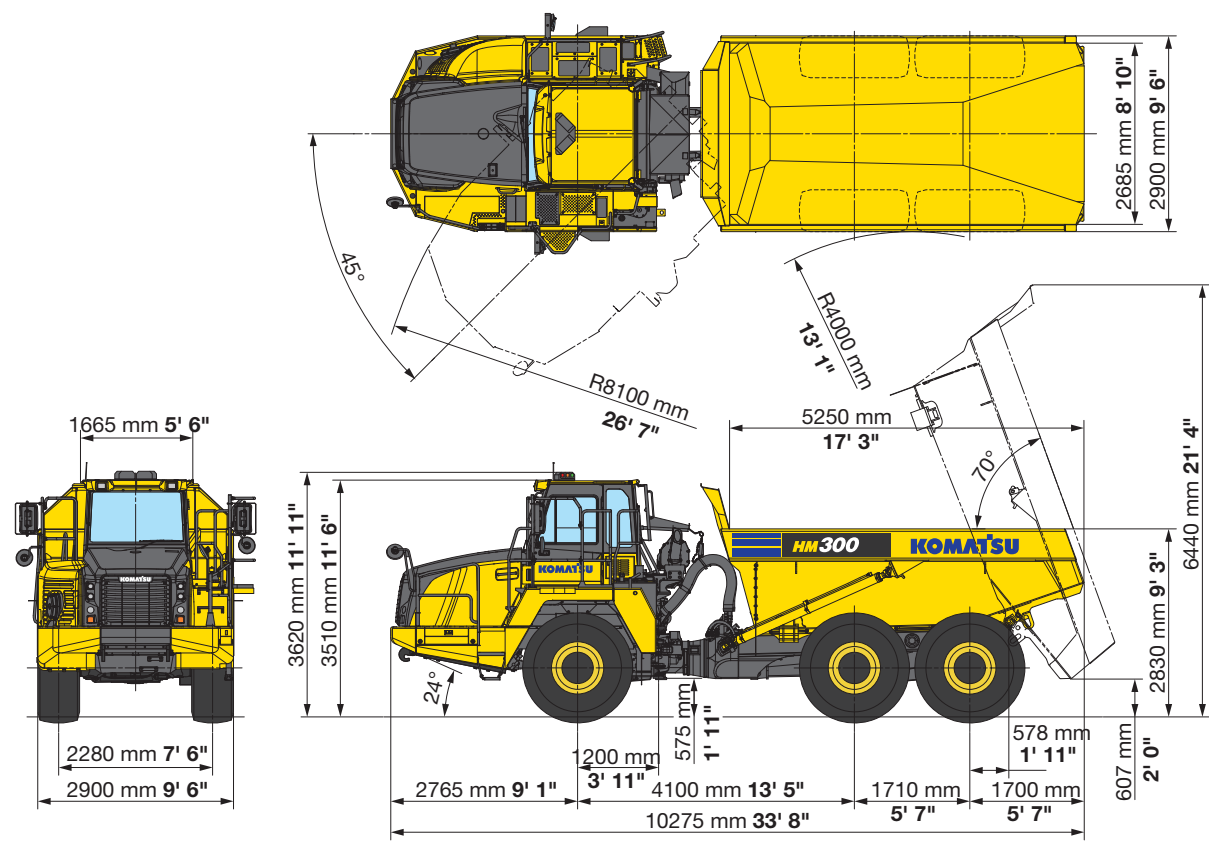

TRAVEL PERFORMANCE (Power mode)

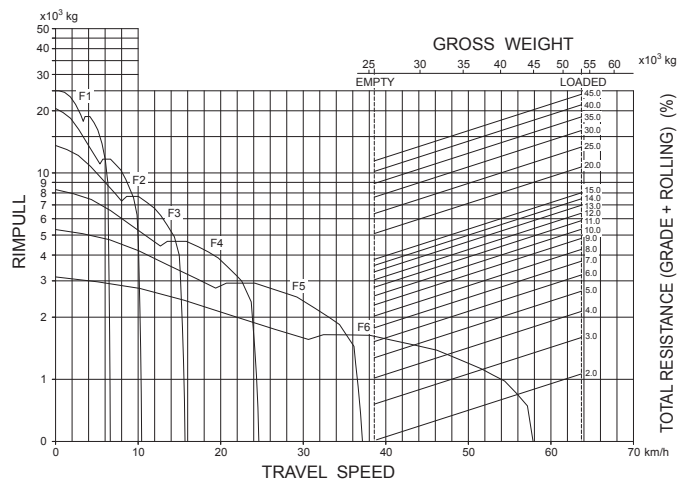

BRAKE PERFORMANCE

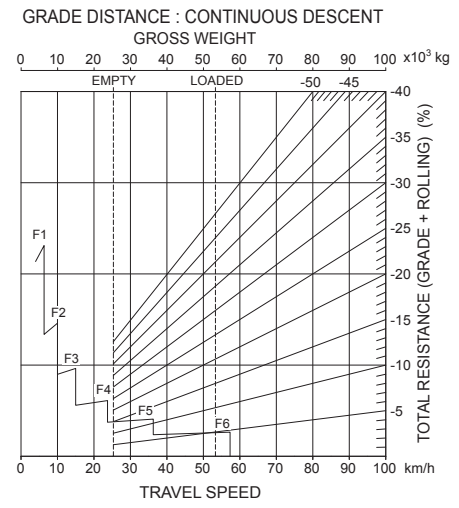

EQUIPMENT



STANDARD EQUIPMENT FOR BASE MACHINE

- Air cleaner, dry type, double elements
- Air cleaner dust level indicator
- Air pre-cleaner
- Alternator, 90 A, 24 V
- Alarm, backup
- Anti-slip material on fenders
- Auxiliary steering system, automatic, electric
- Back-up lamp
- Batteries, 2 x 12 V/200 Ah
- Battery disconnect
- Centralized greasing
- Color rear view camera and monitor
- Coolant temperature alarm and lamp
- Dump counter
- Ecology Guidance
- Electronic hoist control system
- Electric circuit breaker, 24 V
- Electric priming fuel pump
- Electronic pump for hydraulic tilt cab
- Engine, Komatsu SAA6D125E-7
- Engine underguard
- Engine shutdown secondary switch
- Front view mirror
- Full-automatic F6-R2 transmission with lock-up torque converter & K-ATOMiC shift control
- Hazard lamps
- Hand rails for platform and ladder
- Headlights, front (high and low)
- Heated rearview mirrors, LH and RH side
- Horn, electric
- Hydraulic driven cooling fan, for after cooler
- Hydraulic driven cooling fan, for radiator
- Hydropneumatic suspension, front and rear
- Interaxle lockup, wet disc clutch type, controlled by KTCS
- Komatsu Traction Control System (KTCS)
- Komatsu Diesel Particulate Filter (KDPF)
- Komatsu Variable Geometry Turbocharger (KVGIT)
- KOMTRAX®
- Ladders LH side
- Mud guards
- Parking brake
- Payload Meter (PLM)
- Protective grille for rear window
- Propeller shaft guards, front and rear
- Provision for tailgate
- Retarder/brake system
- Rims for 23.5 x 25, set of 6
- ROPS/FOPS cab Level 2
 - 2 x DC12V electrical outlets
 - 12V cigarette lighter
 - Air conditioner/Heater/Defroster
 - AM/FM radio with AUX terminal
- Ashtray
- Color LCD/TFT multi-monitor
- Cup holder
- Floor mat
- Operator seat, reclining, air suspension type with 3-point retractable seat belt, 76 mm **3"** width lap belt, 50 mm **2"** width shoulder belt
- Passenger seat with 2-point retractable seat belt, 76 mm **3"** width
- Power window (LH)
- Space for lunch box
- Sliding window (RH)
- Steering wheel, tilt and telescopic
- Sun visor, front window
- Tilttable ROPS cab with FOPS, sound suppression type
 - Windshield washer and wiper, front and rear
- Selective Catalytic Reduction (SCR) system
- Starting motor, 7.5 kW
- Steering joint locking assembly
- Step (right side)
- Stop, tail, and turn signal lamps (LED)
- Tool box
- Transmission underguard
- Two mode engine power system (Economy and Power)
- Work lamps, LH and RH side



OPTIONAL EQUIPMENT

- 23.5 x 25 tires
- 750/65 R25 rims
- 750/65 R25 tires
- Body, 17.1 m³ **22.4 yd³**
- Body, exhaust heated, 17.1 m³ **22.4 yd³**
- Tail gate, scissors type



Note: All comparisons and claims of improved performance made herein are made with respect to the prior Komatsu model unless otherwise specifically stated.